



Michael Hitchens
National President
NS14 Association of Australia
Mobile: 0404822308
Email: michaelhitchens01@gmail.com

NS14 ASSOCIATION OF AUSTRALIA

MINUTES NATIONAL EXECUTIVE MEETING – AUGUST 2014

Via email from 5 August to 19 August 2014

Agenda

1. Attendance
2. National Measurer
3. Webmaster
4. National Registrar
5. National Treasurer



Item 1: Attendance

All members present:

Michael Hitchens, National President and Treasurer
Bill Kerrigan, ACT President and National Secretary
Shannon Corbett, NSW President
Ashley Barclay, South Australia President
Darren Eggins, Tasmania President
Mike Tait, National Registrar
Rohan Noseworthy, National Measurer
Adrian Adams, Webmaster

Item 2: National Measurer

Following identified exploitations of the upper black band measurement rule, it was recommended that amendments be made to the Class Rules defining sail measurement. The recommendations do not change the application of any existing rule - they are expansion of the application of these rules in the current world.

The rules as currently published allow a suitable method for determining the horizontal measurement plane for the hull (11.3.1). This rule can also be extrapolated to be used for determining the horizontal plane of the black band at 5.50m height. Applying this method however is extremely difficult in practice, and there are now a number of sails being produced which have the 'head' projecting at an angle of greater than 90 degrees to the mast/luff.

The typical mast rake for an NS14 is in the region of 1-4 degrees, and 'informally' albeit, measurement of mainsails took this into consideration and 'allowed' small angles (91-95 degrees approx) of the luff to head angle to allow for the mast rake. Indeed, when sailing to windward, the sails present as level or below the black band. When easing the sail, this immediately results in it projecting above the black band and breaking rule 11.7.1.

Additionally, measuring the sail off the boat doesn't allow for the rules to be applied to their natural conclusion and the exploits we are seeing are a result of this.

NOTE: The sections in BOLD in the Recommended section, are the proposed amendments. The sections in BOLD in the Explanation section are the existing wording and are highlighted to draw attention to the existing relevant rules.

Recommended:

11.6.3. All sails intended for use by a boat racing as an NS14 in accordance with the Class Rules shall be measured by a recognised Club Measurer. The measurer shall initial the sail and mark on it the measured area, **the G length** and the date of measurement in lettering not less than 20mm high. All sails must have a suitable area near the tack for this measurement to be written. A measurer may request a sail to be remeasured at any time at his discretion. The Club Measurer shall forward all measurement forms to his State Measurer.

11.6.8 b) The head of the sail is defined as the point on the Luff, or its extension, level with the highest point of the sail projected perpendicular to **measurement length A - the straight line between the head and the tack of the sail**. The length of any sail with area between the physical sail at the luff and the perpendicular head extension, must be noted in the comments on the sail measurement form and marked as dimension G, in mm, on the sail as per 11.6.3.

Diagram:

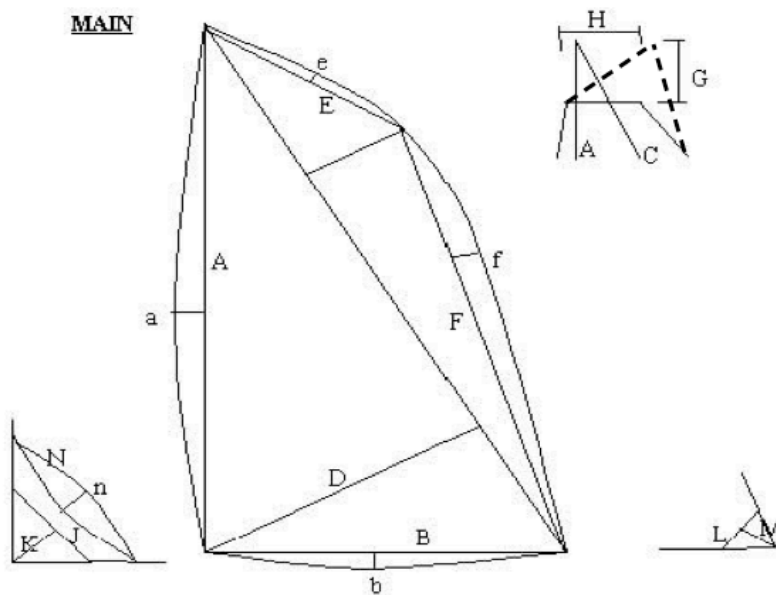

11.7.1 The mast may not extend more than 5650mm above the highest point of the deck including all fixed fittings, but excluding a mastpin. If the mast extends more than 5500mm above the highest point of the deck including all fixed fittings, but excluding a mastpin, the portion of the mast between 5500mm and 5520mm shall be painted a contrasting colour to the mast. No portion of any sail shall set above the bottom of this band. **Any sail with a G length noted on the sail during measurement, must set the physical sail at the luff, this length (G) BELOW this measurement band.**

Explanation. Your attention is drawn to the following rules:

11.3.1. Unless specifically required otherwise hereunder, **all measurements shall be taken parallel to one of the three major axes of the hull vertical, longitudinal or transverse related to the waterline and fore and aft centre line of the hull**. For most boats it is sufficient to estimate the waterline, which runs from near the base of the stem to the base of the transom. **In case of doubt, the measurer may require the waterline to be found with the boat afloat and a crew weight of 130kg positioned as for sailing to windward.**

11.6.8. Measurement Method. The method used to measure sails shall measure surface area as distinct to projected area.

b) The head of the sail is defined as the point on the Luff, or its extension, level with the highest point of the sail projected perpendicular to the Luff or its extension.

11.7.1. The mast may not extend more than 5650mm above the highest point of the deck including all fixed fittings, but excluding a mastpin. If the mast extends more than 5500mm above the highest point of the deck including all fixed fittings, but excluding a mastpin, the portion of the mast between 5500mm and 5520mm shall be painted a contrasting colour to the mast. **No portion of any sail shall set above the bottom of this band.**

Following discussion of some alternatives, it was agreed that the amendments proposed above be put to the National Council.

Item 3: Webmaster

The NS14 website consistently attracts around 14,000 visits per month ... which is a good number.

Since January there has been a trend (except April) where the engagement levels have reduced. Best shown in the number of page views (which have dropped) versus the visits (which have stayed about the same). This is a result of the lack of updates made to content during the season.

One third of the NS14 audience uses mobile devices to view the site ... this time last year it was around 10%.

The Forum is the biggest section of the site followed by NSW, Australia, Contact, SA, News, Tasmania and News.

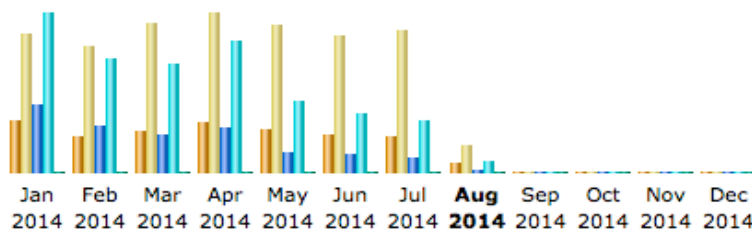

Month	Unique visitors	Number of visits	Pages	Hits	Bandwidth
Jan 2014	4,931	13,235	227,482	533,107	0
Feb 2014	3,460	12,027	158,365	380,519	0
Mar 2014	4,021	14,177	127,746	366,507	0
Apr 2014	4,746	15,085	151,653	442,043	0
May 2014	4,117	14,062	66,829	240,018	0
Jun 2014	3,620	13,029	64,159	195,575	0
Jul 2014	3,406	13,496	50,529	173,921	0
Aug 2014	956	2,545	10,626	38,796	0
Sep 2014	0	0	0	0	0
Oct 2014	0	0	0	0	0
Nov 2014	0	0	0	0	0
Dec 2014	0	0	0	0	0
Total	29,257	97,656	857,389	2,370,486	0

Recommendations

1. Each State to supply a Pre-Season Report/Article and a Calendar of Events.
2. For Championship events ... please supply Sponsors Logos, link to results page, information about the event, travel and accommodation.
3. Any other news or content ... send directly to me and I will publish it on the site
4. Make a decision on which Facebook and Twitter accounts we should link to (the current links go to Hugh Tait's social media pages ... there are others that are more active)

It was agreed that each State would make a greater effort to provide material to Adrian for publication on the website. It was also agreed that the links to Facebook and Twitter should go to the national sites.

Item 4: National Registrar

Advice was sought on how often to publish the national boat register.

It was agreed the register be published on the website twice a year - first a week before the Nationals and second a week before the NSW States.

Item 6: National Treasurer

The bank statements for end June 2014 indicate that we have \$8,673.38 in a term deposit and \$6,582.60 in the operating account.

It was noted that the Association is financially sound.

National President
19 August 2014